



DREX[®]-TOOLS

UTENSILI DI PRECISIONE PER L'INDUSTRIA MECCANICA - AERONAUTICA - AEROSPAZIALE
PRECISION TOOLS FOR THE MECHANICAL AVIATION - AEROSPACE MANUFACTURING



RULLATORE CON DIAMANTE MS2250-25

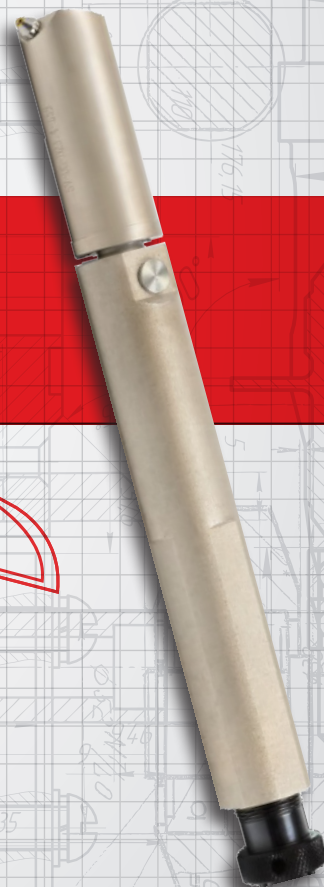
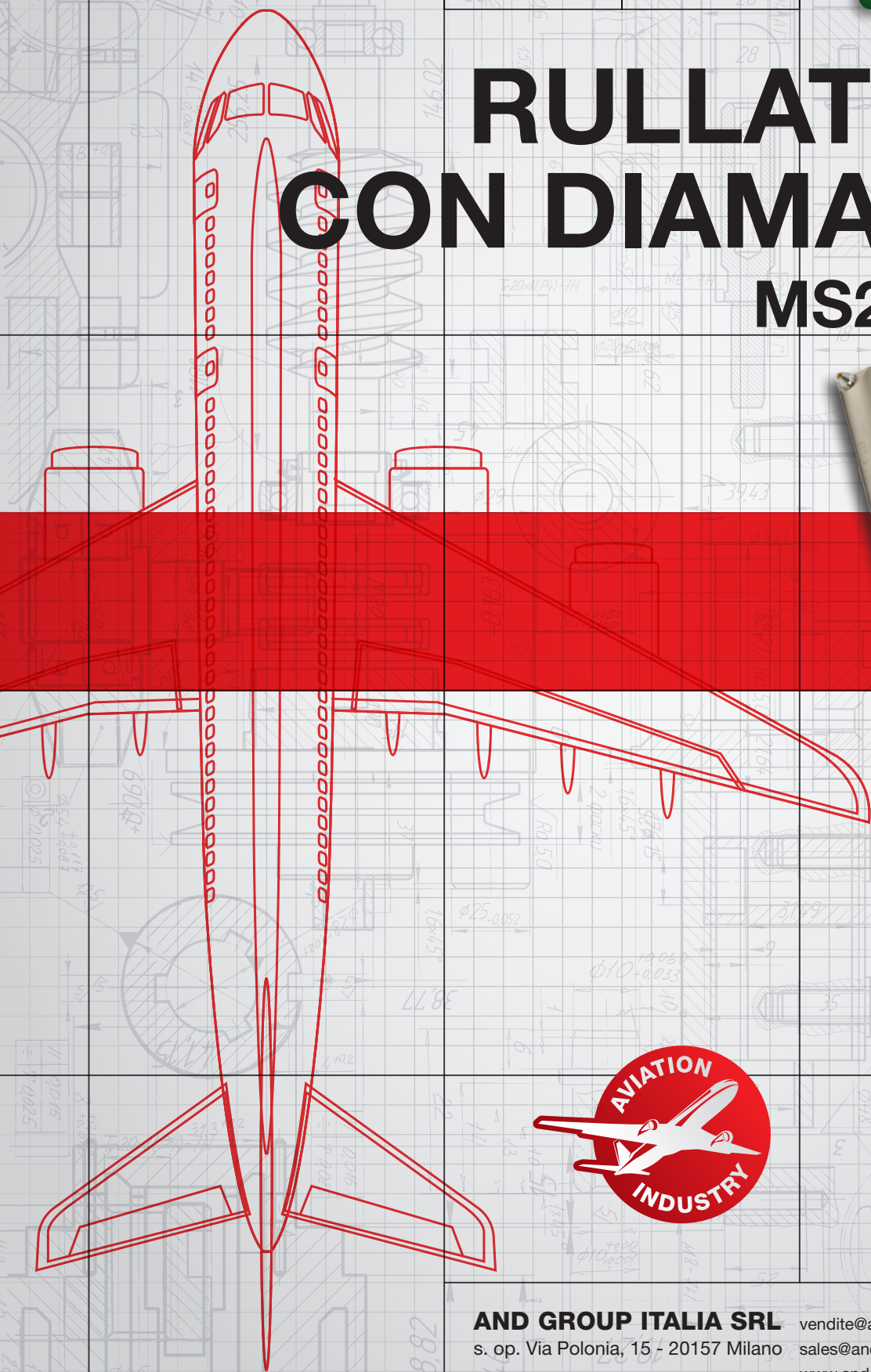

AND GROUP ITALIA SRL vendite@andgroupitalia.com
s. op. Via Polonia, 15 - 20157 Milano sales@andgroupitalia.com
www.andgroupitalia.com



RULLATORE CON DIAMANTE PER FORI SUPER DIAMOND MS2250-25

FORO
INTERNO



DIMENSIONI

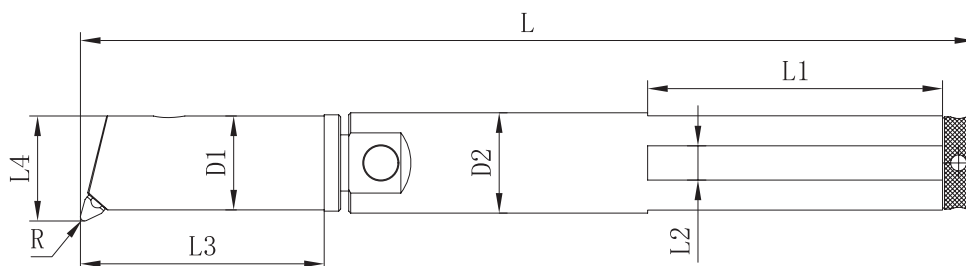

CODICE		L	L1	L2	L3	L4	D1	D2
MS2250-25-R#	-ZB25(MIN28.0)	225	73	8.5	60.5	26.5	23.4	25
MS2250-25-S-R#	-ZB25(MIN28.0)-S	195	73	8.5	30.5	26.5	23.4	25

Per ordinare: inserire il valore del raggio del diamante dopo "R". Gli standards dei raggi dei diamanti sono R 0.75, R 1,00 e R 1.50.
Esempio: se si seleziona la testa del rullo diamantato R 1.00 il codice prodotto è completo.

PEZZI DI RICAMBIO

STELO CON DIAMANTE

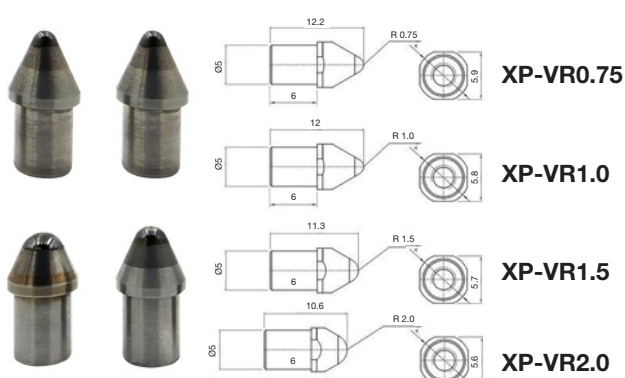

MOLLE

